

乾接點開關模組

Dry Contact Switch Module

P-A-2S1A-DT

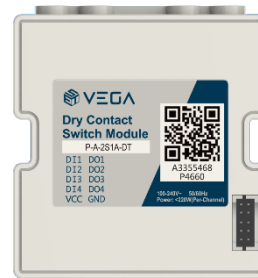

乾接點開關可將普通開關面板、感應器等乾接點設備融入智慧建築系統和平台中，賦予智慧化功能，實現普通開關面板的一鍵多控和情境模式控制，實現普通感應器類產品的狀態回報和遠端控制。

Dry contact switch module can integrate dry contact devices such as ordinary switch panels and sensors into the smart building management system, giving intelligent functions, realizing one-key multiple control of ordinary switch panels, scene mode control, and ordinary sensor products status report and remote control.

性能特點/ Features

- 體積小，86 盒嵌入式安裝
- 電力線載波通訊/支援電力線線上升級
- 二路本地控制/狀態同步
- 超載保護
- Small size, 86 boxes embedded installation
- Power line communication/Supports OTA upgrade
- 2CH local control/status synchronization
- Overload protection

技術參數/ Specifications

- 工作電壓：AC 100V ~ 240V
- 工作頻率：50/60Hz
- 待機功耗：小於 0.5W
- 通訊方式：電力線載波
- 工作溫度：-10°C ~ 55°C
- 工作濕度：10%RH ~ 85%RH
- 外型尺寸(L*W*H)：62.3*58*18.3mm
- Operating voltage: AC 100V~240V
- Operating frequency: 50/60Hz
- Power consumption: < 0.5W
- Communication: Power line communication (PLC)
- Ambient temperature: -10°C ~55°C
- Ambient humidity: 10%RH ~ 85%RH
- Dimensions(L*W*H): 62.3*58*18.3mm

接線圖/ Wiring Diagram

live wire live wire live wire
output 2 output 1 neutral wire

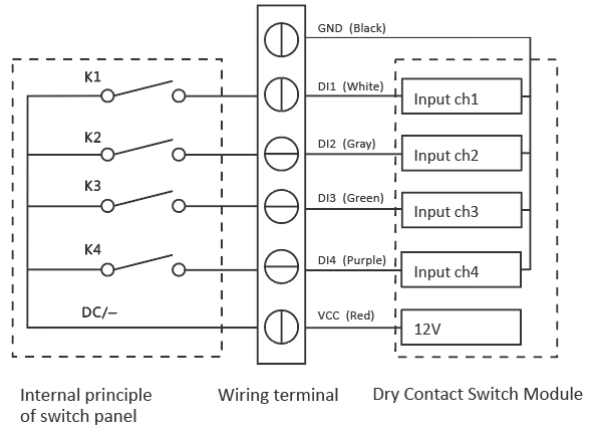
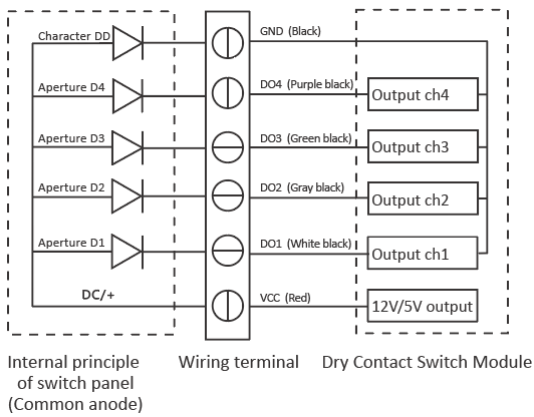
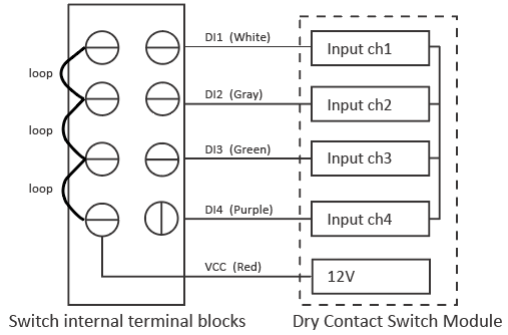
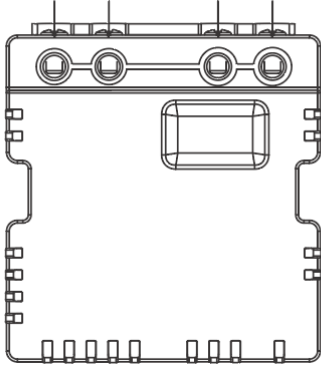

訂貨型號/ Order Model

P-A-2S1A-DT